



# **AUTOMOTIVE**

*Electrical test applications*



# DRIVING YOUR ELECTRICAL TESTING FORWARD.

**As vehicles become more autonomous, testing safety systems as well as EV power cables, wire harnesses, door systems and chassis assemblies testing is more vital than ever before.**

We're working with a growing number of customers in the automotive industry, particularly eVehicles and eTrucks, performing high voltage, high current testing as well as functional component testing.

EV testing demands the automotive industry to move away from green-light red-light testing, and embrace recording of every test to understand failures and enable rework.

Cable assemblies represent one of the higher cost components and they are safety-critical components often carrying 400VDC – 800VDC. Bond testing is also an important test, to ensure passenger safety.

This brochure provides an overview of test applications within the automotive sector, and our recommended product solution.

## CONTENTS

|   |   |
|---|---|
| Our role within your production environment | 2 |
| Customers                                   | 3 |
| Applications & recommended products         | 4 |
| Product overview                            | 5 |
| Test management software                    | 7 |
| About MK Test Systems                       | 8 |



# OUR ROLE WITHIN YOUR PRODUCTION ENVIRONMENT

Testing the electrical wiring in automotive vehicles is carried out at multiple stages throughout the manufacturing process.

Our tools carry out the full range of test required at each of these stages to ensure every assembly is wired correctly, enabling you to fulfil your QA commitments before the harness or sub-assembly can move to the next stage.

We also offer systems which have full functional capabilities for final assembly testing, ensuring safety systems and active components such as mirrors and lights are fully operable.

*Harness shop*

*Sub assembly*

*Final assembly*



# SOME OF OUR AUTOMOTIVE CUSTOMERS



DAIMLER TRUCK  
North America



## CUSTOMER CASE STUDIES & TESTIMONIALS



*"The MK system improves production and ensures we deliver superior products to our customers, faster."*

Eddie Smith – CEO, Trysome Group



*"The F2500 delivers quality of results and flexibility...exactly what we asked for."*

Santon Switchgear were using a variety of manual methods to test switch connections at their Rotterdam facility, which was resulting in a slow production rate and an inconsistent quality control process.

When they briefed MK Test Systems for a solution, the key requirements were "efficiency, speed, flexibility and reliability".

Since implementing the Automeg F2500 into their production processes, Santon have been able to reduce a 1 hour test down to just 5 minutes, a 91% reduction in testing time.



### SANTON SWITCH TO AUTOMATED TESTING TO SAVE TIME & IMPROVE QUALITY

Slow, manual testing has been switched for a highly automated "all-in-one" method since Santon Switchgear implemented the F2500 Automeg into their production process.

#### THE PROBLEM

Santon were using a variety of manual methods to test switch connections at their Rotterdam facility, which included wiring all measurements by hand for just one of the many test stages.

This was resulting in a slow production rate and an inconsistent quality control process.

It was clear the processes could be improved in several ways. "Efficiency, speed, flexibility and reliability" were the key requirements for the project team.

Read more about the **SOLUTION** from MK Test Systems over the page.

**CUSTOMER:** Santon Switchgear

**REGION:** EMEA

**SOLUTION:** F2500 Automeg

**APPLICATION:** CBM automeg for isolation, Power & Control, Defence, Rail and Subsea testing

**OUTCOME:** Quality improvement for testing increased production rate

**BENEFITS:** Faster switchgear testing with higher error margin



**91%**  
Reduction in testing time

**1hr**  
to 5min



# APPLICATIONS & RECOMMENDED PRODUCTS

## Wire & cable harness testing

Automatic test solutions for electrical harnesses and assemblies. Recommended products are Automeg models T, F or D; RTS.

## Equipped assembly / function testing

Automatic test solutions for electrical assemblies and active components such as relays and switches. Recommended products are Automeg models E or M.



## Function testing

Automatic functional testing solutions for safety systems and active components such as mirrors, lights and door systems. Recommended products are Automeg models E or M.

## High voltage (HV) insulation cable testing

Automatic test solutions for electrical harnesses and assemblies. Recommended products are Automeg models T, F or D.



# PRODUCT OVERVIEW

**We offer an extensive range of electrical harness test systems, and have the modular flexibility to customise all models to suit your exact requirements.**

Our sales team can help you configure the perfect spec for your needs, but this guide is a useful starting point. As an overview, all models offer the following features:

- Continuity resistance measurement, low voltage isolation test (short circuit), and high voltage DC insulation resistance testing as standard.
- Optional high voltage AC HiPot testing, capacitance measurement LCR modules
- Optional function test stimulus switching modules and power supplies to enable actuation and function test. Note: This option is suitable for testing a small number of active components in the assembly under test. For testing larger amounts of active components, we recommend a full function test system from our E or M series.
- Integration with a range of third party sources, scopes and measurement modules.
- MKAT, our test management software which combines ease of use with powerful test program creation and management capabilities. Learn more about MKAT on page 7.

All systems can be configured to suit your operation and application, from static rack cabinets to heavy duty mobile cabinets suitable for harness shop floor or final assembly environments. We also offer distributed and fully portable systems.

## **Our range of Automeg models break out into the following groups:**

**T Series:** This model is named T for two wire, because our T series applies 2 wire continuity resistance measurement. If your test requirement demands a high test point count and only needs continuity resistance measurement down to  $0.1\Omega$ , then the T series is your entry level, lowest cost, automatic test option.

**F Series:** The F series is our dedicated 4 wire test Kelvin measurement solution. As per the T model range, F stands for four wire. When your continuity and resistance measurements need to be milliohm-accurate, the dedicated 4 wire F system guarantees you the best possible accuracy. This series is therefore ideal for testing critical cables, components, shielding joints and low resistance connections.

**D Series:** The D series is our most popular model for standard electrical harness testing. It offers both 2 wire and 4 wire resistance measurements, as well as the ability to mix these modes in a single test program. The D series models can handle a mix of resistance measurements down to  $2m\Omega$ . The result is an extremely flexible system which enables rapid automatic testing of complex assemblies.

Continued over the page...



**E Series:** The E series is our entry level multibus function test solution. If your product has active components or you might need to function test active assemblies in the future, the E series offers both measurement and function test capability. Each E series relay card can be used as either a measurement card or a functional stimulus switching card. The only restriction with the E series is that the card can be used for either measurement or stimulus switching during a subtest, so you need to plan your test interface to enable a full functional test. The E series is your ideal solution if active component density is low or your designs are stable.

**M Series:** The M Series offers the highest level of flexibility. These systems can be used in both 2 wire and 4 wire kelvin measurements and they can also deliver functional stimulus from any test at any time. As with the E series, the card can be used for either measurement or stimulus switching during a subtest. The M series simplifies your interface design as each interface channel can be used to both measure and stimulate, so no need for a complex Y cable interface. For example, when testing a contactor the system measures the resistance of a coil and then stimulates the coil using the same test points and same interface wire. It then measures the change in contact resistance concurrently. If your active component density is high, or your active product format is flexible then the M series is your ideal system.

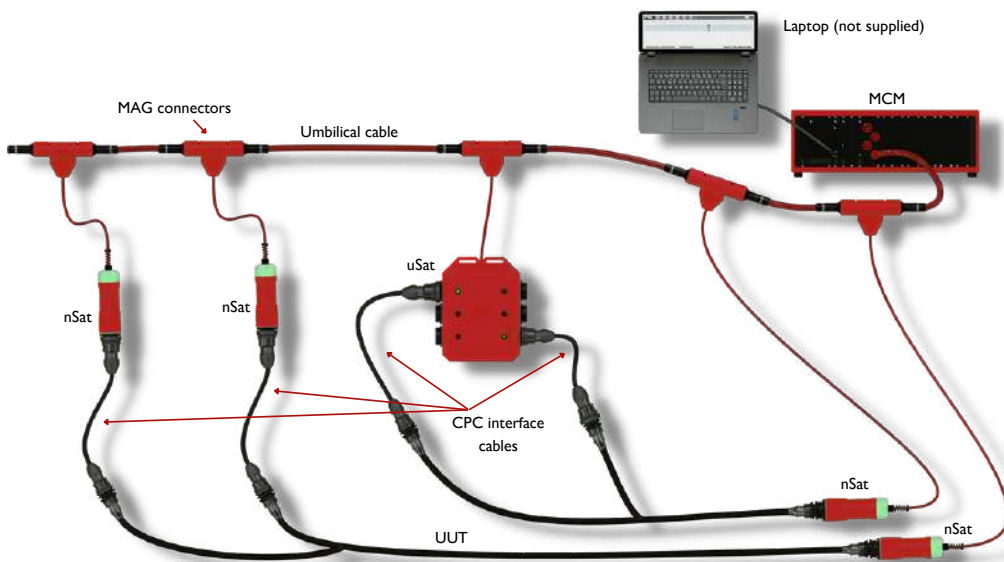

**RTS:** Separate from the Automeg range, RTS is an entirely different type of wire harness test system.

It's a miniaturised, modular product which brings the test points directly to the unit under test, thereby eliminating up to 90% of interface cables typically required with a traditional system.



The key to understanding which system is the right one for you is knowing your test requirements.

Ideally, you'll be able to tell us the following details:

- Number of test points (to test a single 2 wire if required, 4 for kelvin measurements)
- Maximum voltage required for AC and DC insulation tests
- If you require a static, mobile or distributed system
- Your interface requirement – standard or custom
- Is energisation required? If so, what is the maximum current and voltage?
- Do you require high current switching (more than 2 Amps)?
- Do you need to test capacitance?

Our sales team can advise on the best system for you and recommend any additional modules.

# MKAT TEST MANAGEMENT SOFTWARE

*"From creation of test programs through to fault diagnostics, MKAT supports your business needs whilst giving engineers control over testing."*

*In our 2022 survey, 87% of our customers said MKAT software was easy to use.*

All MK Test systems run on MKAT, our test management software combining our renowned ease of use with highly advanced technology. It's all driven by our goal of simplifying the test process for our customers.

## Simplifying the testing process at every stage

Whilst we pride ourselves on the robustness and reliability of our hardware, it is our software which makes our systems stand out from our competitors.

We've spent years developing and refining our software to make it simple to use yet powerful.

## Creating the test program

Create a test program without having to learn a programming language. We use standard wiring input of Netlist, connection tables and interface adaptor tables to create test programs.

Test parameters such as current, voltage, resistance and dwell can be set by test, group or connection. Tests are enabled or disabled by simple click of a button.

## APG

Automatic Program Generation (APG) is included in the MKAT test management software as standard.

Our APG toolset allows the user to re-map fields and use their existing data formats.

## Ease of use

Creation of the test program is only the start – our software makes the test process simple.

Operator instructions and prompts can be easily added to any program, and automatic test reports and fault diagnosis tools inform the operator of the nature of the failure and how to fix or retest the fault.

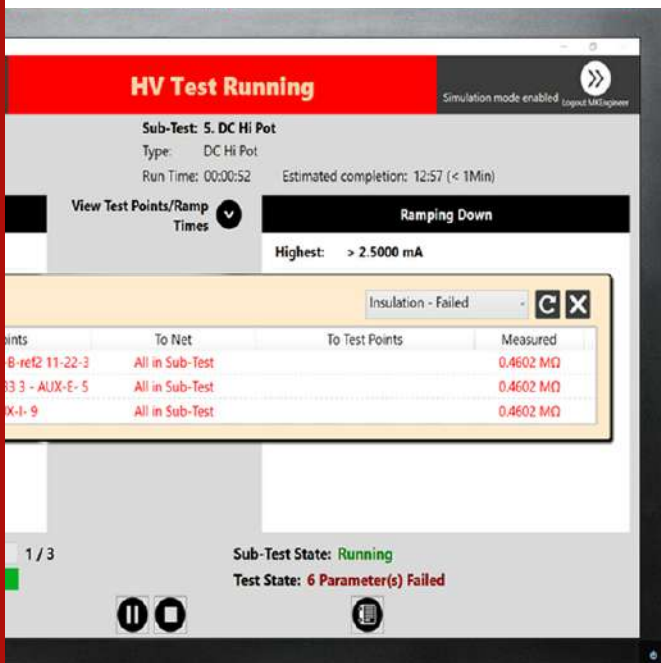



## ABOUT US

We've been designing and manufacturing automatic electrical test equipment for over 30 years. In that time, we've provided systems to customers around the world, in the following industries:



- Aerospace
- Automotive
- Defence
- Industrial, Power & Control
- Subsea
- Trains

Our range of products enable rapid, automatic testing of engines, wiring harnesses, slip rings and other vital components.

We can work with you wherever testing is undertaken, at any stage of the product lifecycle. This may be at component manufacture stage - providing quality assurance to subcontractors - or at the final assembly stage, ensuring complete confidence in the final product. Beyond this, we also provide testing solutions for MRO and servicing.

## TALK TO US

Our UK head office is supported by satellite locations in the US and Hong Kong. With our large global network of reps and distributors, you can be assured of local support, sales and training.

For your local contact details, please visit our website, [www.mktest.com](http://www.mktest.com).

## FOLLOW US

