



AEROSPACE

Electrical test applications



www.mktest.com

RAISING YOUR QUALITY ASSURANCE SKY-HIGH.

Since 1991, our automatic test equipment has enabled manufacturers of aircraft, engines and sub-assemblies as well as maintenance operators to efficiently test electrical wiring and measure lightning protection, HIRF protection and ground circuits.

We enable some of the biggest names in the aerospace sector to efficiently and accurately perform high voltage testing.

As an OEM, whether you need a solution for a harness shop, airframe section equipping or final assembly line, our range of ATE can test your products quickly and accurately.

MRO facilities can be assured that our equipment meets OEM requirements - we're listed in Boeing AMMs and offer equivalency for Airbus.

Our tools and equipment combine powerful features with easy-to-use software and interfaces - designed to make testing simpler and faster.

Testing capabilities across our range includes continuity resistance; short circuit; HV insulation resistance; HiPot (dielectric withstand); functional testing of active components; isolation testing; capacitance; and bond, loop & joint resistance testing.

This brochure provides an overview of test applications within the aerospace sector, and our recommended product solutions for every stage of the product's lifecycle.

CONTENTS

Our role within your business	2
Customers	3
Applications & recommended products	4
Products overview	5
Test management software	8
About MK Test Systems	9

OUR ROLE WITHIN YOUR BUSINESS

From wire harness and OEM sub-assembly manufacturing through to routine MRO maintenance, testing is an essential - in many cases mandatory - element of an aircraft's lifecycle.

MK Test Systems have been working within the aerospace industry for over 30 years. In that time, we've developed electrical test equipment and procedures supporting leading manufacturers, suppliers and MROs, including Airbus and Boeing.

There are very few elements on an aircraft that don't require comprehensive electrical testing, and MK's extensive product and specifications provide a complete solution no matter where in the supply chain or product lifecycle your business operates.



SOME OF OUR AEROSPACE CUSTOMERS



CUSTOMER CASE STUDIES & TESTIMONIALS

AIRBUS

Airbus have installed the RTS high speed wire harness system on their A320 FAL in Toulouse, France.

“RTS is an innovative solution compared to traditional wiring testers. It allows workload reduction by fast set-up and fast testing.”

Olivier Boizot - Project Leader, Airbus



Heart Aerospace are currently using BLRT on their preproduction electric aircraft.

“We're using the BLRT to check the electrical bonding on test rig ground planes. It would not be possible to check the resistance of these connections with a normal point-to-point bond tester as so many parallel paths exist.

The addition of joint test functionality allows us to find high impedance interfaces quickly.

We've been able to avoid making expensive ground planes from one piece of metal by using this functionality.”

Andy Palmer - Senior Environmental, HIRF, & Lightning Qualification Engineer, Heart Aerospace

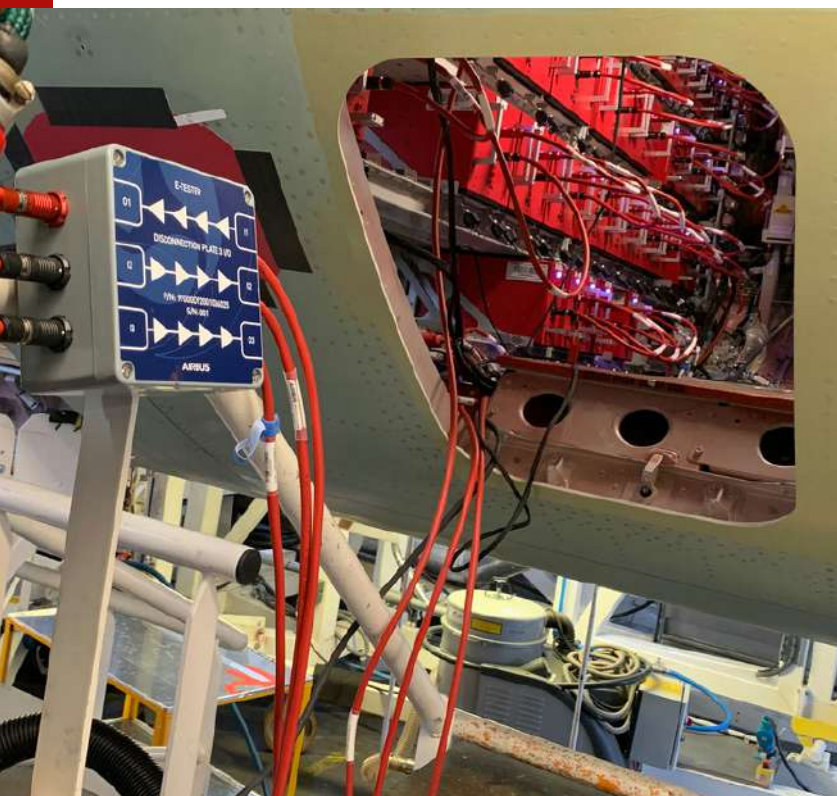

APPLICATIONS & RECOMMENDED PRODUCTS

Wire / Cable Harness Testing

Automatic test solutions for electrical wire harnesses and cable assemblies. Products: Automeg, RTS.

Aircraft Engine Testing

Automatic test solutions for electrical wire harness and components; electrical bond circuits, earth straps and shielded cables. Products: Automeg, Portable Automeg.



Final Assembly Line (FAL)

Automatic testing of complete aircraft. Products: Automeg, RTS.

Connector Testing

Automatic testing of electrical connector assemblies. Products: Automeg.

Bond, Loop & Joint Testing

Automatic resistance testing to ensure low resistance current paths. Products: ExLRT, BLRT, BLTU.

Equipped Assembly / Function Testing

Automatic test solutions of electrical assemblies and active components. Products: Automeg.

WIRE HARNESS TEST SYSTEMS

We offer an extensive range of electrical harness test systems, and have the modular flexibility to customise all models to suit your exact requirements.

Our sales team can help you configure the perfect spec for your needs, but this guide is a useful starting point. As an overview, all models offer the following features:

- Continuity resistance measurement, low voltage isolation test (short circuit), and high voltage DC insulation resistance testing as standard.
- Optional high voltage AC HiPot testing, capacitance measurement LCR modules
- Optional function test stimulus switching modules and power supplies to enable actuation and function test. Note: This option is suitable for testing a small number of active components in the assembly under test. For testing larger amounts of active components, we recommend a full function test system from our E or M series.
- Integration with a range of third party sources, scopes and measurement modules.
- MKAT, our test management software which combines ease of use with powerful test program creation and management capabilities. Learn more about MKAT on page 7.

All systems can be configured to suit your operation and application, from static rack cabinets to heavy duty mobile cabinets suitable for harness shop floor or final assembly environments. We also offer distributed and fully portable systems.

Our range of Automeg models break out into the following groups:

T Series: This model is named T for two wire, because our T series applies 2 wire continuity resistance measurement. If your test requirement demands a high test point count and only needs continuity resistance measurement down to 0.1Ω , then the T series is your entry level, lowest cost, automatic test option.

F Series: The F series is our dedicated 4 wire test Kelvin measurement solution. As per the T model range, F stands for four wire. When your continuity and resistance measurements need to be milliohm-accurate, the dedicated 4 wire F system guarantees you the best possible accuracy. This series is therefore ideal for testing critical cables, components, shielding joints and low resistance connections.

D Series: The D series is our most popular model for standard electrical harness testing. It offers both 2 wire and 4 wire resistance measurements, as well as the ability to mix these modes in a single test program. The D series models can handle a mix of resistance measurements down to $2m\Omega$. The result is an extremely flexible system which enables rapid automatic testing of complex assemblies.

Continued over the page...



E Series: The E series is our entry level multibus function test solution. If your product has active components or you might need to function test active assemblies in the future, the E series offers both measurement and function test capability. Each E series relay card can be used as either a measurement card or a functional stimulus switching card. The only restriction with the E series is that the card can be used for either measurement or stimulus switching during a subtest, so you need to plan your test interface to enable a full functional test. The E series is your ideal solution if active component density is low or your designs are stable.

M Series: The M Series offers the highest level of flexibility. These systems can be used in both 2 wire and 4 wire kelvin measurements and they can also deliver functional stimulus from any test at any time. As with the E series, the card can be used for either measurement or stimulus switching during a subtest. The M series simplifies your interface design as each interface channel can be used to both measure and stimulate, so no need for a complex Y cable interface. For example, when testing a contactor the system measures the resistance of a coil and then stimulates the coil using the same test points and same interface wire. It then measures the change in contact resistance concurrently. If your active component density is high, or your active product format is flexible then the M series is your ideal system.

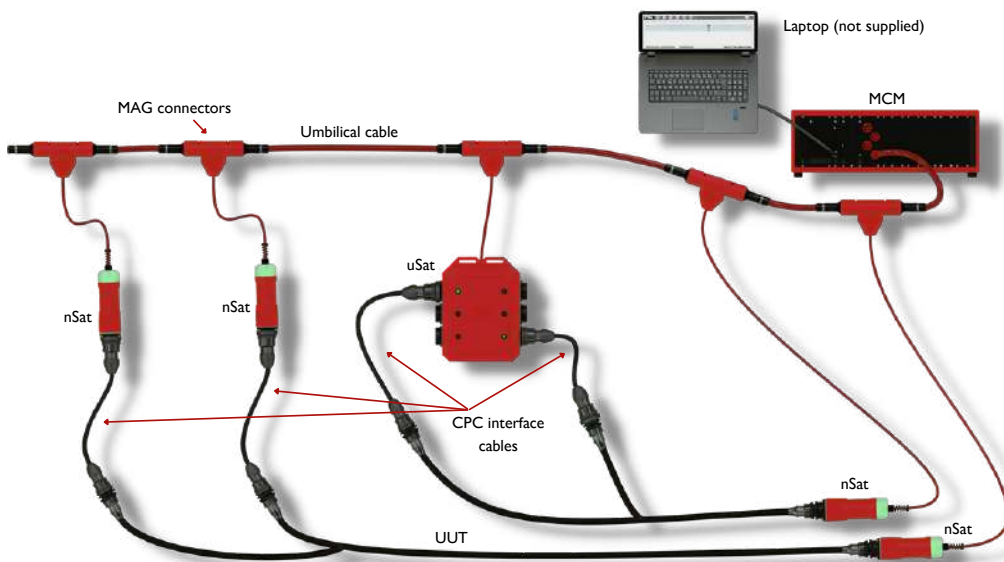

RTS: Separate from the Automeg range, RTS is an entirely different type of wire harness test system.

It's a miniaturised, modular product which brings the test points directly to the unit under test, thereby eliminating up to 90% of interface cables typically required with a traditional system.



The key to understanding which system is the right one for you is knowing your test requirements.

Ideally, you'll be able to tell us the following details:

- Number of test points (to test a single 2 wire if required, 4 for kelvin measurements)
- Maximum voltage required for AC and DC insulation tests
- If you require a static, mobile or distributed system
- Your interface requirement – standard or custom
- Is energisation required? If so, what is the maximum current and voltage?
- Do you require high current switching (more than 2 Amps)?
- Do you need to test capacitance?

Our sales team can advise on the best system for you and recommend any additional modules.

BOND & LOOP RESISTANCE TESTING

We've developed our range of tools specifically to resolve the inherent issues with the legacy 'yellow box' LRT equipment.

Our range of tools are lightweight, operator-friendly and we have models approved for use by Boeing and Airbus.

Whether you need simple loop tester or need to carry out full Bond, Loop & Joint testing, we have a suitable tool for you.

The comparison table below shows the differences between our models and the 'yellow box' LRT.



	LRT (THE YELLOW ONE)	BLRT / BLTU4 (THE ORANGE ONES)	EXLRT (THE RED ONE)
IS CLASSIFICATION	Class 1 Division 2 (Flammable gases not likely to exist)	N/A	Class I, Division 1 (Flammable gases exist all the time)
OPERATORS	2	1	1
TEST MODES	Manual	Manual & automatic	Manual & automatic
PROGRAMMABLE	No	Yes	No
USER INSTRUCTIONS	No	Full graphics in auto mode	Text instructions in auto mode
RESULTS	None	Auto save to tool & network	Auto save to tool & network
CALIBRATION	Turn-around time 2 months	Turn-around time 1 week	Turn-around time 1 week
WEIGHT	17kg / 37.5lbs	7kg / 15.5lbs	3kg / 6.6lbs
BOND / LOOP / JOINT	No / Yes / Yes	BLRT/BLTU4 - Yes / Yes / Yes	No / Yes / Yes
APPROVAL	Boeing	Airbus & Boeing	Airbus (via equivalency) & Boeing

MKAT TEST MANAGEMENT SOFTWARE

"From creation of test programs through to fault diagnostics, MKAT supports your business needs whilst giving engineers control over testing."

In our 2022 survey, 87% of our customers said MKAT software was easy to use.

"When combined with our Multibus test module, the Active APG tool provides world leading function test capability."

All MK Test systems run on MKAT, our test management software combining our renowned ease of use with highly advanced technology. It's all driven by our goal of simplifying the test process for our customers.

Simplifying the testing process at every stage

Whilst we pride ourselves on the robustness and reliability of our hardware, it is our software which makes our systems stand out from our competitors.

We've spent years developing and refining our software to make it simple to use yet powerful.

Creating the test program

Create a test program without having to learn a programming language. We use standard wiring input of Netlist, connection tables and interface adaptor tables to create test programs.

Test parameters such as current, voltage, resistance and dwell can be set by test, group or connection. Tests are enabled or disabled by simple click of a button.

APG

Automatic Program Generation (APG) is included in the MKAT test management software as standard.

Our APG toolset allows the user to re-map fields and use their existing data formats.

Ease of use

Creation of the test program is only the start – our software makes the test process simple.

Operator instructions and prompts can be easily added to any program, and automatic test reports and fault diagnosis tools inform the operator of the nature of the failure and how to fix or retest the fault.

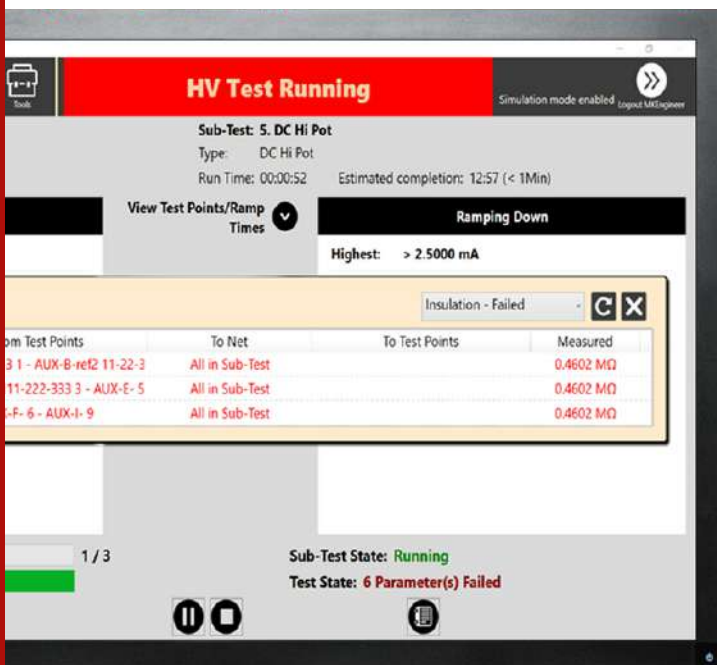

ABOUT US

We've been designing and manufacturing automatic electrical test equipment for 30 years. In that time, we've provided systems to customers around the world, in the following industries:



- Aerospace
- Automotive
- Defence (US DoD CAGE code 8EGR1)
- Industrial, Power & Control
- Subsea
- Trains

Our range of products enable rapid, automatic testing of engines, wiring harnesses, slip rings and other vital components.

We can work with you wherever testing is undertaken, at any stage of the product lifecycle. This may be at component manufacture stage - providing quality assurance to subcontractors - or at the final assembly stage, ensuring complete confidence in the final product. Beyond this, we also provide testing solutions for MRO and servicing.

TALK TO US

Our UK head office is supported by satellite locations in the US and Hong Kong. With our large global network of reps and distributors, you can be assured of local support, sales and training.

For your local contact details, please visit our website, www.mktest.com.

FOLLOW US

